

R. LEAVITT.
SEWING MACHINE.

No. 30,634.

Patented Nov. 13, 1860.

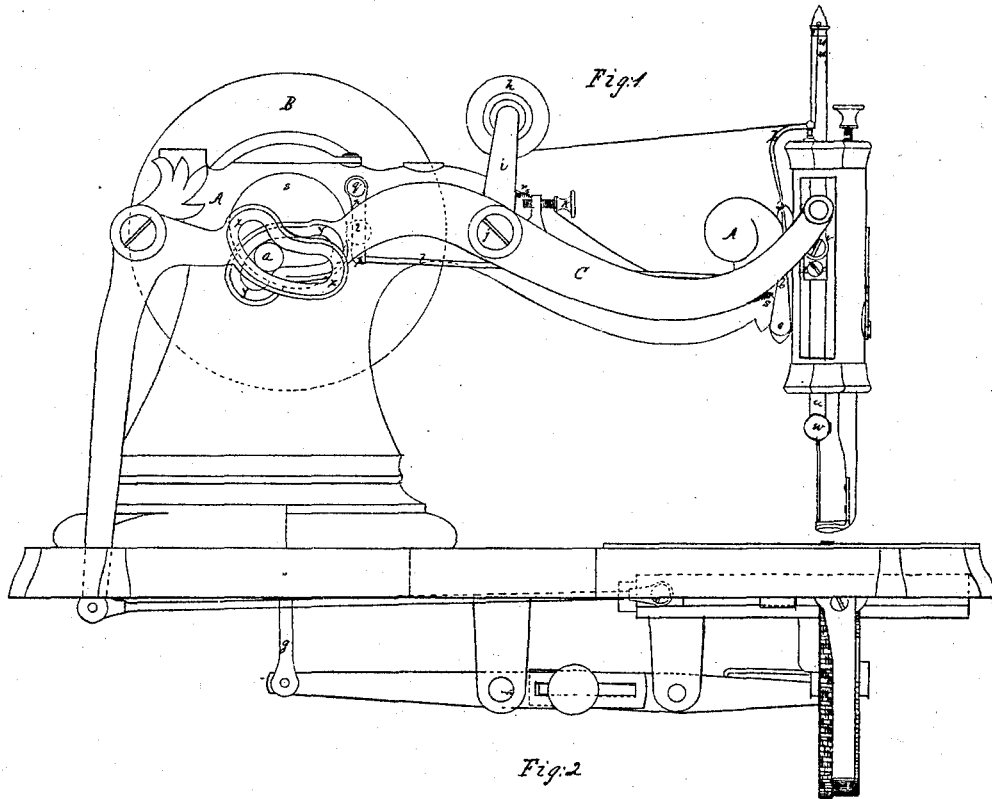
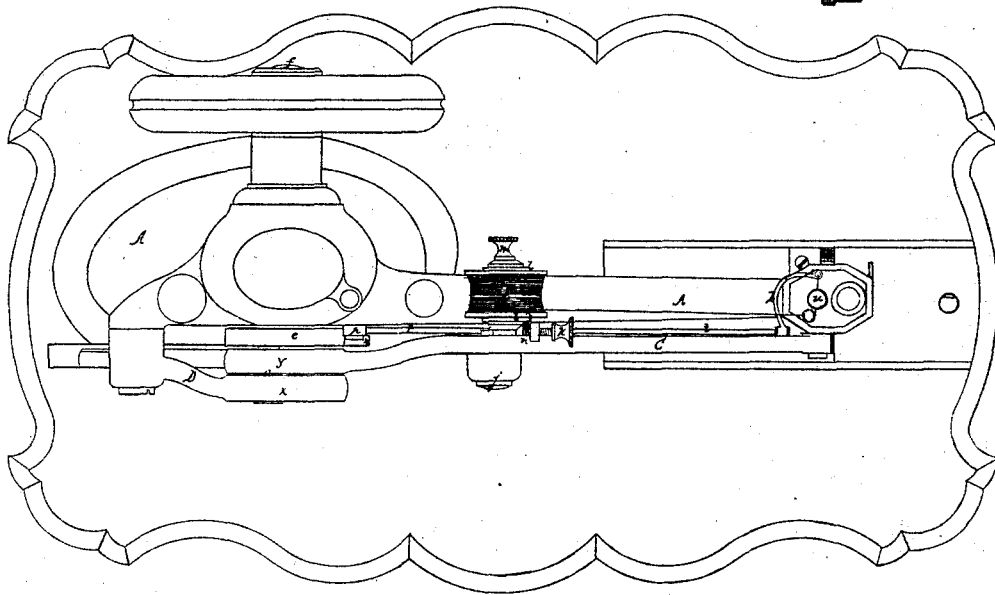

Fig. 1



Witnesses.

J. B. Smith
Wm. B. Gleason

Inventor
Rufus Leavitt

R. LEAVITT:
SEWING MACHINE.

No 30,634.

Patented Nov. 13, 1860.

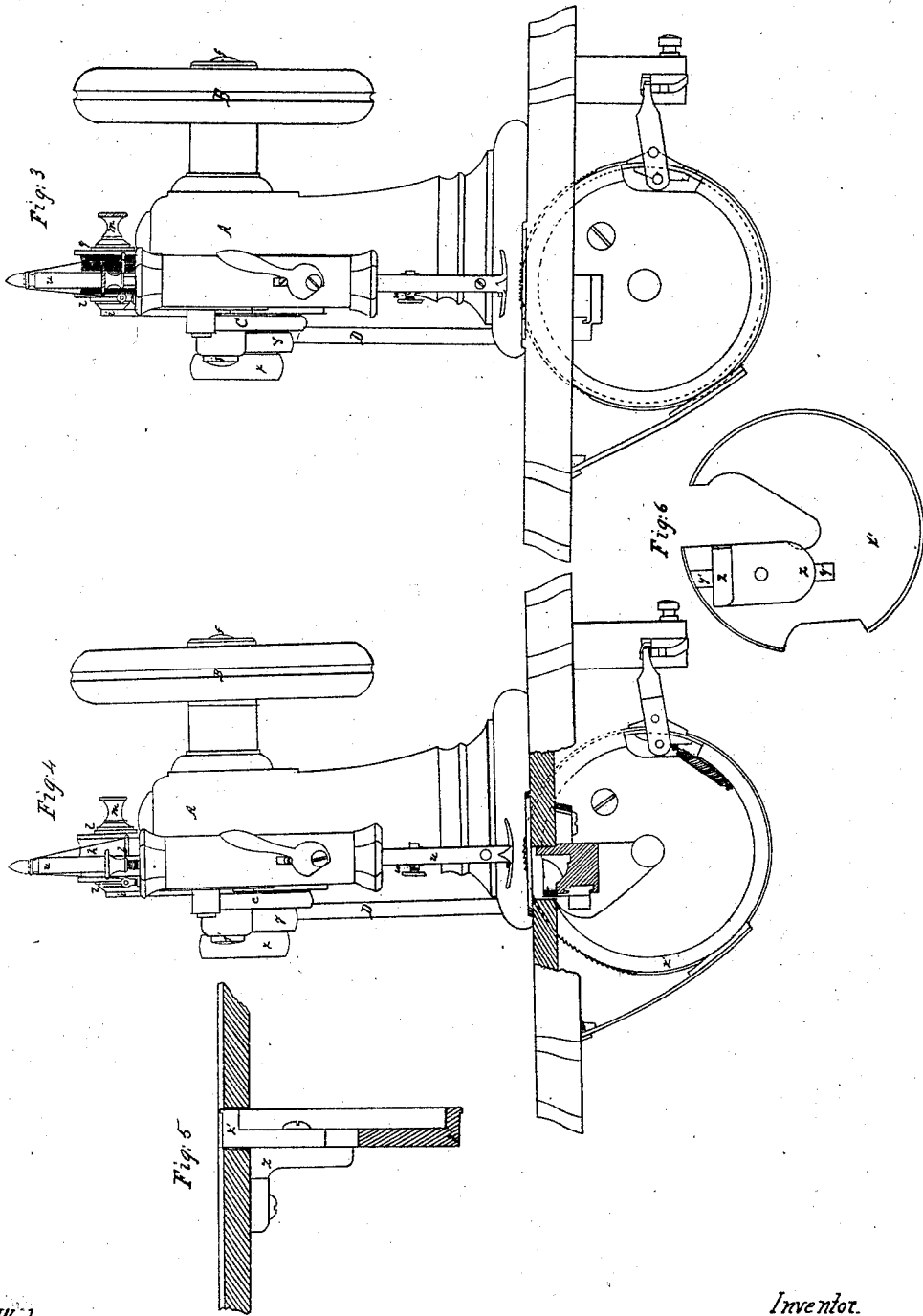

Witnesses.
A. B. Green
Wm. B. Mason

Inventor.
Rufus Leavitt

UNITED STATES PATENT OFFICE.

RUFUS LEAVITT, OF MELROSE, MASSACHUSETTS.

IMPROVEMENT IN SEWING-MACHINES.

Specification forming part of Letters Patent No. 30,634, dated November 13, 1860.

To all whom it may concern:

Be it known that I, RUFUS LEAVITT, of Melrose, in the county of Middlesex and State of Massachusetts, have invented certain new and useful Improvements in Sewing-Machines; and I do hereby declare that the following, taken in connection with the drawings which accompany and form a part of this specification, is a description thereof so full and exact as to enable those skilled in the art to practice my invention.

The variety of sewing-machines to which my invention particularly applies is well known as the "shuttle-machine."

My invention relates to an arrangement and combination of parts by which I am enabled, at or about the last part of the upward throw of the needle, to take off from the spool holding the needle-thread a sufficient amount for the formation of each stitch, thereby dispensing with a length of reciprocation of the needle, which, but for these parts, would be necessary for this purpose and for no other, leaving the thread slack between the eye of the needle and the spool at the time when the shuttle passes between the needle and its thread, drawing down the latter and causing it to render through the eye of the former and the different parts back as far as the spool; also, to a new combination of parts operating to take up the slack of the needle-thread during the descent of the needle to the goods, to prevent kinking around and under the needle, or other entanglement of the thread, which it leaves free from its influence throughout the other portions of the stroke of the needle.

Similar letters refer to similar parts in the different figures of the drawings, in which—

Figure 1 is a side elevation, Fig. 2 a plan, and Fig. 3 an end elevation, of a sewing-machine embodying my invention. Fig. 4 is the same with Fig. 3, with exception that part of the bed is shown as removed to exhibit the construction and manner of attachment of the part on which the feed-ring rotates, which is further illustrated in the detail drawings, Figs. 5 and 6.

The machine illustrated in the drawings and embodying my invention does not differ materially in its feed, its shuttle and needle, presser-foot, and general relation of the bed and arm or "goose-neck" from others now public. These parts therefore, and their operation are

sufficiently well known to those skilled in the art not to need description in this specification, which will be confined nearly as possible to the parts effected, or modified by or embraced in the combinations of my invention.

The shaft *f*, to which motion is communicated to operate the sewing mechanism, passes through the upper and rear part of the arm *A*, as shown in the drawings.

At the end opposite to that on which the hand-wheel *B* is located, a disk, *E*, is fixed, whose periphery is cam-shaped for the purpose of operating, in connection with the other means shown in the drawings and hereinafter described, the take-up *b*. In the disk *e* a crank-pin, *a*, is fixed, which, in its rotation, operates upon the cams *x* and *y*, formed, as illustrated, at the ends of the needle and shuttle levers *C* and *D*, thus giving to the needle and shuttle, through the connections plainly shown in the drawings, the amount and times of linear movement and rest therefrom requisite (proper and common) for such instruments in their action in a sewing mechanism. As the form of these cam-shaped slots requires to be varied in machines of different sizes and for various kinds of work, and as I make no claim to the shape of the cam-slots, I do not herein give any rule for their shape, which can only be got at by actual reduction to practice of theory by those skilled in mechanism.

Upon the shaft *f* and within *A* is fixed the belt-pulley, by which the machine can be operated. In one side of this pulley a cam is cut, which, through *g* and other illustrated parts, operates the feed. The pulley and cam not appearing in the drawings are here mentioned solely for that reason. The spool *h* for the needle-thread is pivoted upon a stud fixed in arm *i*, which is pivoted upon the stud *j*, on which the needle-lever *C* vibrates. A projection from *C* is arranged so as to strike *i* during that part of the vibration of *C* which raises the needle, moving the spool back from the needle-bar, and taking off from it a length of thread proportionate to the amount of the throw given to the spool. This saves an amount of vibration of the needle-bar which would otherwise have to be given it to take off thread enough from the spool to form each stitch, which amount is saved by movement of my take-off, which is easily adjustable in the amount of its throw to the requirements of the

seam: but to change the throw of the needle, to take off from the spool different lengths of thread, would seriously interfere with the movements of other parts. The spool is drawn toward the needle-bar during the other part of the vibration of C by contraction of the spiral spring *n*, and the extent of the movement of the spool is regulated by the position of the set-screw *k*, which can be adjusted so as to give any desired amount of throw to the spool called for by the requirements of the seam; or it can prevent any throw of the spool, in which case its take-off function is rendered inoperative. Tension upon the thread is obtained and varied by increasing or diminishing the friction between the spool and the washers *l* by adjusting the nut *m*.

The device which is termed a "take-up" operates to take up the slack thread left during the descent of the needle to the fabric, which, if not taken up, would be liable to interfere by entanglement with the operations of the sewing mechanism.

My take-up consists of the piece *b*, pivoted at *o*, and so formed that the thread passes through an eye or hook formed in its free end. A lever, *p*, is pivoted at *q*, carrying a roll, *r*, which is made to bear against the cam-shaped periphery of the disk *e*. The tendency of the spiral spring *s* to contract when extended, it being fixed by its ends to the goose-neck and to the take-up *b*, acts to keep the latter drawn back toward the disk or cam *e*, and through the rod *t* keeps the roll *r* on lever *p* constantly pressed against the cam *e*, which, by means of the same rod, *t*, communicates its throw to the take-up *b*, at the same time extending the spiral spring *s*. The eye of the take-up *b* remains in the line of the thread drawn from the eye of the needle to the guide-hole in the top of the needle-bar during the whole of the upward stroke of the needle; but as the downward stroke thereof commences it moves off toward spool *h*, taking up the slack formed in the thread by the descent of the needle-bar and by the forward throw of the spool, thus keeping the slack from kinking or getting entangled around the needle. When the needle-point is fairly entered into the goods, then the take-up moves forward to assume its place in the line before mentioned, where it remains till the commencement of the next downstroke of the needle. The movements of my take-up are regulated in extent and time by the cam *e*, the spring *s* keeping the roll *r* constantly pressed against the cam; but it will be obvious that when any unusual occurrence takes place by which the strain on the thread is increased, the yielding of the spring will in many cases prevent the breakage of the thread, which would occur if the take-up was obliged to follow with a positive motion the movement of the cam. I am aware that there have been, previous to my invention, take-ups which had the function of mine—viz., to keep the slack of the thread formed by the descent of the needle from entanglement; but

the difference between such take-ups and mine is shown by the difference of their action on the thread during the upstroke of the needle.

The take-ups referred to may be classified into two kinds. In one of these the take-up instrument has a spring movement in one direction, uncontrolled except by the tautness of the thread to take it up till the needle enters the work, and then the take-up has a positive retrograde movement imparted to it equal to or in excess of the further movement of the needle, so that there may be sufficient slack in the needle-thread to permit the passage of the shuttle between the needle and its thread; but during the upstroke of the needle, after the take-up is released from the mechanism which moved it positively, as before referred to, the spring acts again with its full force directly upon the thread, which is objectionable, as causing want of uniformity in the stitches and unnecessary wear upon and rendering of the thread. In this kind of take-up the instrument has no positive movement imparted to it during the upstroke of the needle, as do the take-ups of the second kind, for the purpose of tightening the stitches, the operation of the second kind of take-ups being otherwise substantially the same with that of the first kind. A peculiar instrument for controlling the needle-thread may be found in the English Patent No. 2,649 for the year 1855. This does not, like my take-up, operate to keep the thread taut between the needle-eye and the fabric during the descent of the former to the latter, but works in the reverse manner and continues operating after the needle has entered the goods to form slack in the thread to facilitate the passage of the shuttle, and afterward to tighten the stitch by pulling on the needle-thread, which is wound around the instrument to obtain the requisite degree of tension on the thread. My take-up operates only to keep the thread from kinking and entangling from the first part of the downstroke of the needle till this enters the work. It does not pull from the spool any thread to give a large loop for the passage of the shuttle, but simply leaves the thread loose and free between the needle and the tension, so that the shuttle (entering between the needle and its thread) draws upon the latter sufficiently to pass through. Neither does my take-up operate or aid in any way to draw in or tighten the stitches. The function of my take-up is precisely that of an instrument in common use in shuttle-machines, which will be recognized, when its action is described, to be that of the finger and thumb seizing the thread between the point of the needle on its downstroke and the goods, and drawing it away from the needle in the direction of the feed till the needle-point enters the goods, when the thread becomes disengaged from such nippers by being pulled out of their grasp by movement of the sewing mechanism. But my take-up has these advantages over that last described: It is less in the way of the operative, and not liable to

be caught in the work, is not so subject to derangement, and is more easily and cheaply combined with the sewing mechanism.

I do not claim any other than the specific device operating to yield when required and to take up the slack of the thread during the downward movement of the needle, and at once returning to its position in the normal line of the thread.

In sewing-machines it is a desideratum to make all the rapidly-reciprocating parts light as possible. Any device, therefore, which enables me to use a light needle-bar is of importance.

The bar *u* has a collar, *d*, around it, which may be adjusted anywhere on the length of the bar by a set-screw, *c*. To this collar and to the vibrating lever *C* the link *v* is connected. It will be observed that by slackening the set-screw in *d* the needle-bar may be adjusted with reference to the distance of its end from the table, and by removing the needle-clamp *w* the bar may be entirely withdrawn from the machine without disturbing other parts thereof.

In other shuttle-machines in which the feeding-instrument is a serrated ring, through which the shuttle-race passes, the carrier of the ring has formed part of the bed of the machine or of some portion thereof, or has had projections not concentric with the center of the ring cast upon it. In all of these the turning of the ring-seat has been made inconvenient by reason of the parts attached to the carrier, which also prevents its easy finish in the lathe. To remedy this inconvenience, to cheapen the cost, and increase the finish of

the machine, I leave off from the carrier *x'* all such projections as are not concentric with it, such as ears and straight flanges. Upon the center I have a hub cast of sufficient size to hold the carrier firmly on the arbor while it is turned, which hub may afterward be cut off. In the plane side of *x'* a groove, *y'*, is burred out, and the right-angled knee *z* is formed with a projection on one of its faces, fitting the groove. The screw which holds the carrier to *z* plays in a slotted hole in the carrier, by which the feed-ring is set to any desired height above the table, the knee being firmly screwed to the bed.

I claim in a sewing mechanism—

1. The arrangement and combination of the spool *h* with the lever *C*, or other moving part of the mechanism whose movement is uniform with and relative to that of the needle, and with the screw *k* or other equivalent means of adjustment, and spring *n*, all operating together in relation to the movement of the needle, substantially as and for the purpose specified.

2. The employment of the take-up for the specified purpose, in combination with a spring and cam, both arranged and operating together to give the take-up the movement due to the form of the cam, except when from strain upon the thread it is requisite for the take-up to yield to avoid breakage of the thread, which yielding the spring as applied permits.

RUFUS LEAVITT.

Witnesses:

T. B. CROSBY,
W. H. CADES.